

REV.	MODIFICATION.	DATE	DRN
01	CO2010267	24/09/08	SF
02	CO2011021	16/11/10	SF

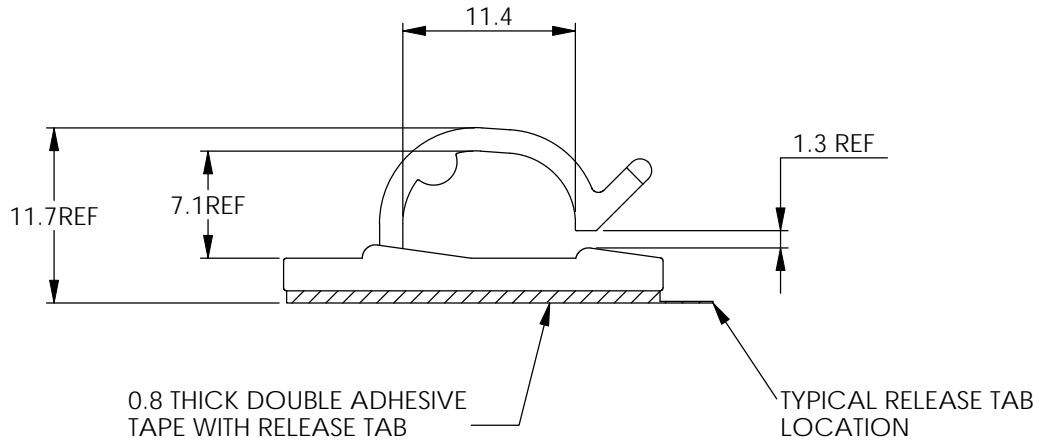
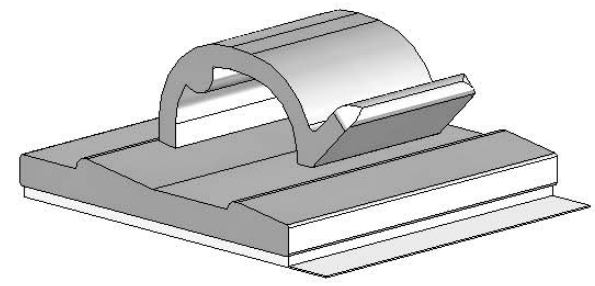
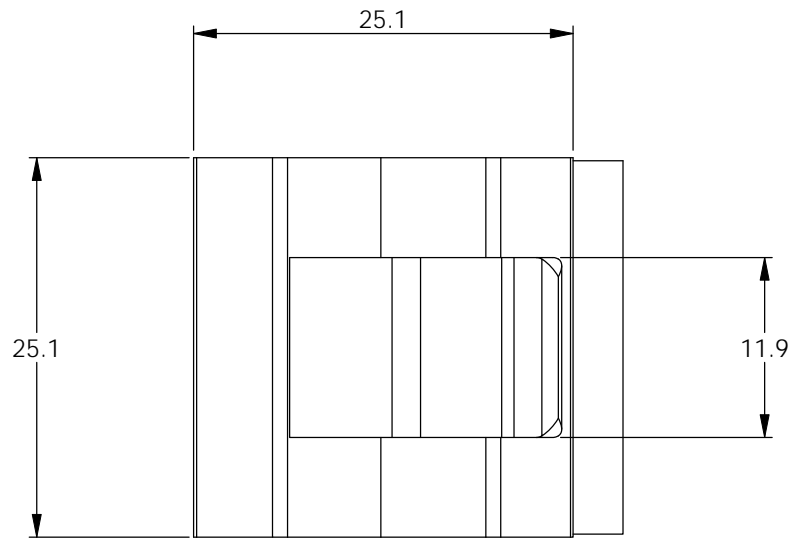

INFORMATION CONTAINED IN THIS DOCUMENT IS CONFIDENTIAL TO RICHCO INTERNATIONAL Co. Ltd. AND MAY NOT BE DISCLOSED OR REPRODUCED IN WHOLE OR PART WITHOUT THEIR WRITTEN CONSENT.

<b>RICHCO, INC.</b> <a href="http://WWW.RICHCO-INC.COM">WWW.RICHCO-INC.COM</a>	ALL DIMENSIONS IN mm GENERAL TOLERANCES $\pm 0.25$ UNLESS OTHERWISE STATED 1 DECIMAL PLACE $\pm 0.25$ 2 DECIMAL PLACES $\pm 0.10$ ANGULAR $\pm 1^\circ$	THIRD ANGLE 
---	--	-----------------

PART NUMBER	MATERIAL	
WCK-460-01A4-RT	NYLON 6/6 UL94 V-2(RMS-01)	ADHESIVE TAPE (RMS-024)
WCK-460-01		-
WCK-460-19A4-RT	NYLON 6/6 UL94 V-0(RMS-19)	ADHESIVE TAPE (RMS-024)
WCK-460-19		-

MATERIAL: SEE TABLE		COLOR: NATURAL	
DESCRIPTION: WIRE CORD KLIP		PART No: SEE TABLE	
DRG No: 08-098	NPR No: N/A	Mass:(g) 0.7	SHEET SIZE A4
DRN SF	DATE 24/09/08	CHKD TC	DATE 24/09/08
SCALE NTS		SHEET No. 1 OF 1	