

DATASHEET

Thermal Protector F06

Type series 06

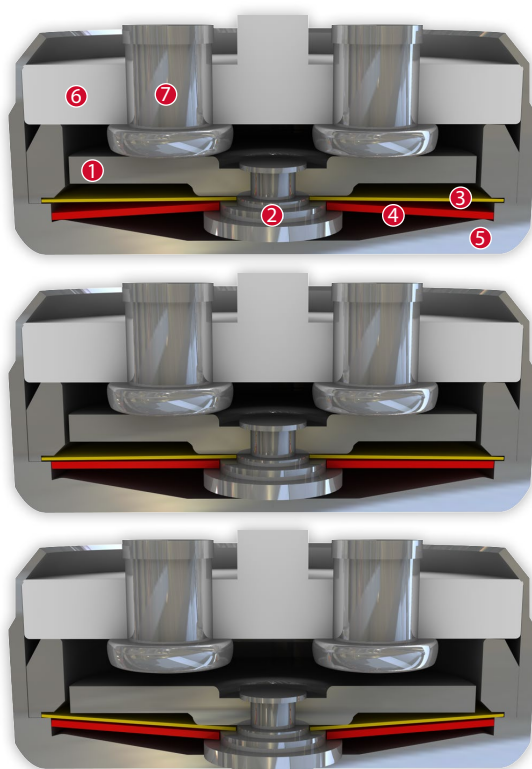

Construction and function

Switchgear consisting of a mobile and circular contact bridge (1), a contact bearing pin (2), a spring snap-in disc (3) and a bimetallic disc (4) which is riveted into one another, undetachable and fixed in a positive lock and self-aligning between a non-conductive floor of a housing (5) and an insulating ceramic bearing (6) with two integrated stationary contacts (7) as electrodes. At the same time, the switchgear is supported by the spring snap-in disc (3) with the contact bridge (1) acting as a transfer element for electric current which is held between a supporting collar and a circumferential ring. As such, the bimetallic disc (4) underlying it, that is also stuck out from the contact bearing pin (2), can continuously work (exposed) by mechanical loads without the contact pressure defined by the spring snap-in disc (3) diminishing. As soon as the bimetallic disc (4) reaches its rated switching temperature, it effectively springs against the throw force of the spring snap-in disc (3) into its inverted position. The contacts are abruptly opened. The temperature will now fall. The bimetallic disc (4) will only snap back upon reaching a defined reset temperature and the contacts will be closed again. As the contact bearing pin (2) is appropriately dimensioned, an easy, circular rotation of the circle-shaped contact bridge (1) is enabled with every switch so that transfer resistances remain constantly below the minimum limit after many switch cycles and the long term stability is sustained even under high levels of stress.

Features:

Strong power density	Strong currents in small types of construction
Quick response sensitivity	Featured by small protector mass and the metal-housing
Excellent long term performance	Due to instantaneous switching, fine silver contacts, constant contact resistance and to electrically as well as mechanically unstrained bimetallic disc, reproducible switching temperature values
Very short bouncing times	< 1 ms
Instantaneous switching	With always constant contact pressure up to the nominal switching point, resulting in low contact stress
Temperature resistance	By use of high temperature resistant materials and components



F06

Type: Normally closed; resets automatically; with connector cables; with epoxy; fully insulated in a Nomex® cap

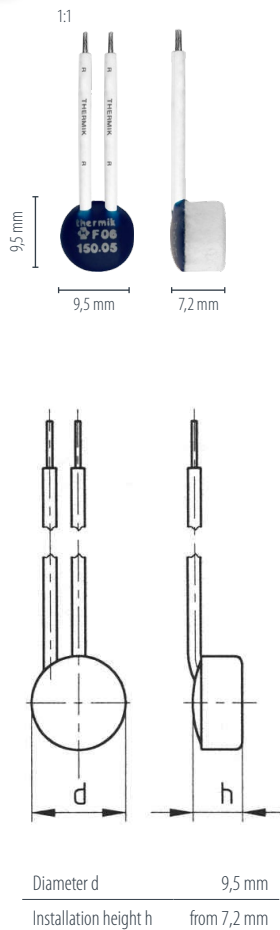

Nominal switching temperature (NST) in 5 °C increments	70 °C - 200 °C	
Tolerance (standard)	±5 K	
Reverse Switch Temperature (defined RST is possible at the customer's request)	UL	≥ 35° C (≤ 95° C NST)
		-50 K ± 15 K (≥ 100° C ≤ 180° C NST)
		-65 K ± 15 K (≥ 185° C ≤ 200° C NST)
	VDE	≥ 35 °C
Installation height	from 7,2 mm	
Diameter	9,5 mm	
Resistance to impregnation *	suitable	
Suitable for installation in protection class	I + II	
Pressure resistance to the switch housing *	600 N	
Standard connection	Lead wire 0,75 mm ² / AWG18	
Available approvals (please state)	IEC; ENEC; VDE; UL; CSA; CQC	
Operational voltage range AC/DC	up until 500 V AC / 28 V DC	
Rated voltage AC	250 V (VDE) 277 V (UL)	
Rated current AC cos φ = 1.0/cycles	10,0 A / 10.000	
Rated current AC cos φ = 0.6/cycles	6,3 A / 10.000	
Max. switching current AC cos φ = 1.0/cycles	25,0 A / 2.000	
Rated voltage DC	24 V	
Max. switching current DC/cycles	40,0 A / 8.000	
High voltage resistance	2,0 kV	
Total bounce time	< 1 ms	
Contact resistance (according to MIL-STD. R5757)	≤ 50 mΩ	
Vibration resistance at 10 ... 60 Hz	100 m/s ²	

Current sensitivity characteristic at I_{nom}:

- dependent of...
- Thermal coupling
 - Application area
 - Built-in conditions
 - Outer influences
 - Wiring length / wiring diameter

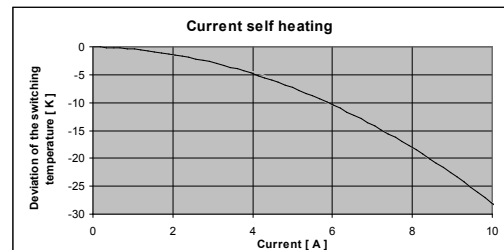

Ordering example:



Marking example:



More varieties of the type series 06:

- C06 – with connector cables; with epoxy; without insulation
- S06 – with connector cables; with epoxy; insulation: Mylar®-Nomex®
- L06 – with connector cables; with epoxy; fully insulated in a screw on housing
- P06 – with connection pins; with epoxy; fully insulated in the attachment housing
- V06 – with connector cables and double-insulated in the attachment housing
- B06 – with connector cables; with epoxy; fully insulated in a Ryton® cap
- C06HT – with connector cables; silicone coated; without insulation
- S06HT – with connector cables; silicone coated; insulation: PTFE
- H06 – with connector cables; with epoxy; fully insulated in the attachment housing

- www.thermik.de/data/C06
- www.thermik.de/data/S06
- www.thermik.de/data/L06
- www.thermik.de/data/P06
- www.thermik.de/data/V06
- www.thermik.de/data/B06
- www.thermik.de/data/C06HT
- www.thermik.de/data/S06HT
- www.thermik.de/data/H06

*In accordance with the Thermik test. Specifications relating to part applications (on the part of the buyer) which deviate from our standards are not checked for their capacity to support an application and/or conformity with standards. The responsibility for testing the suitability of Thermik products for such applications falls upon the user. • Slight deviations are possible in terms of dimensions/ values, depending on the embodiment of the product. • We reserve the right to make technical changes in the course of further development. • Details concerning certain data, measurement methods, applications, approvals, etc. can be supplied upon request.